

DISCLAIMER: The use of this standard is governed by the "Texas Engineering Practice Act". No warranty of any kind is made by TxDOT for any purpose whatsoever. TxDOT assumes no responsibility for the conversion of this standard to other formats or for incorrect results or damages resulting from its use.

DATE: FILE:

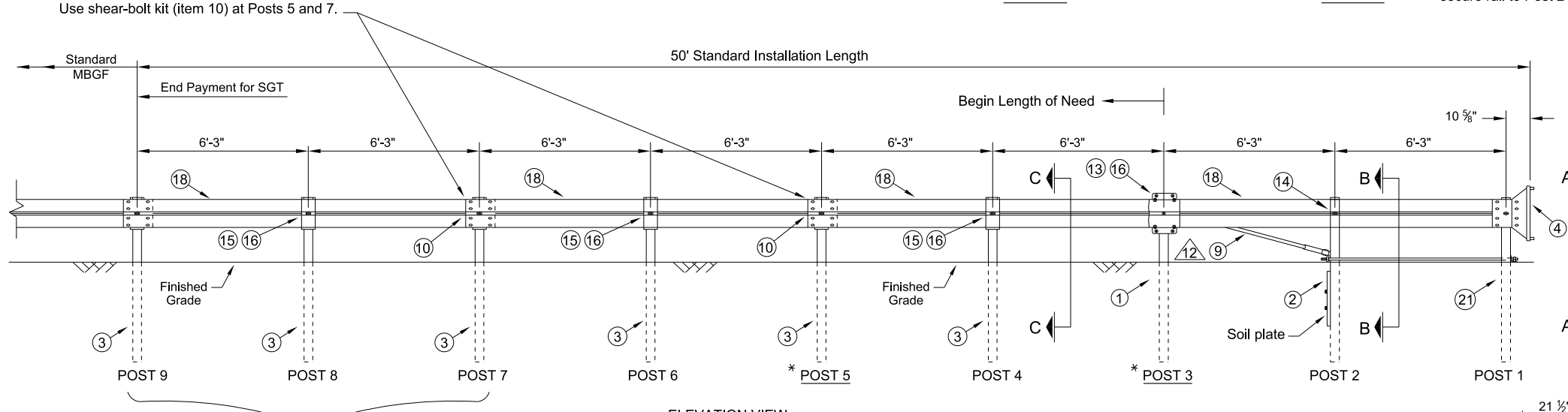

See Note 10 for alternate post option.

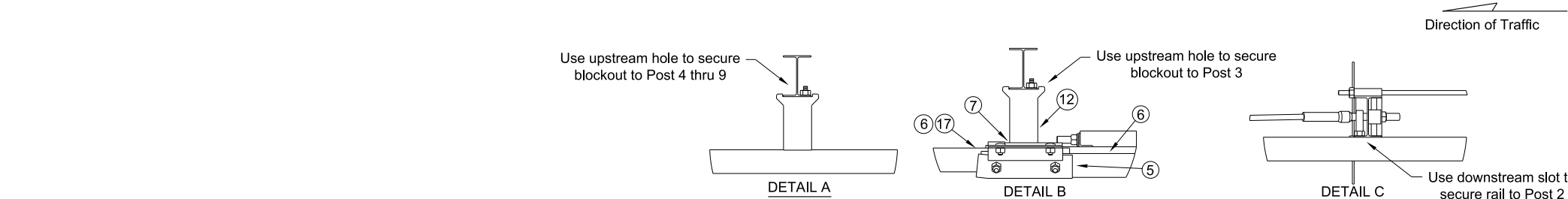
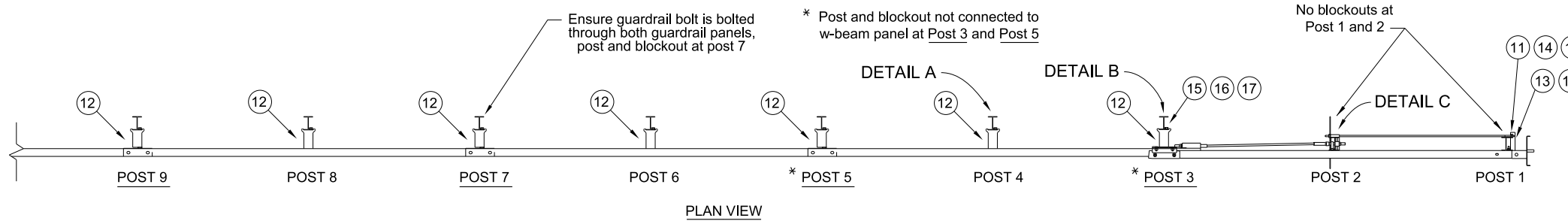
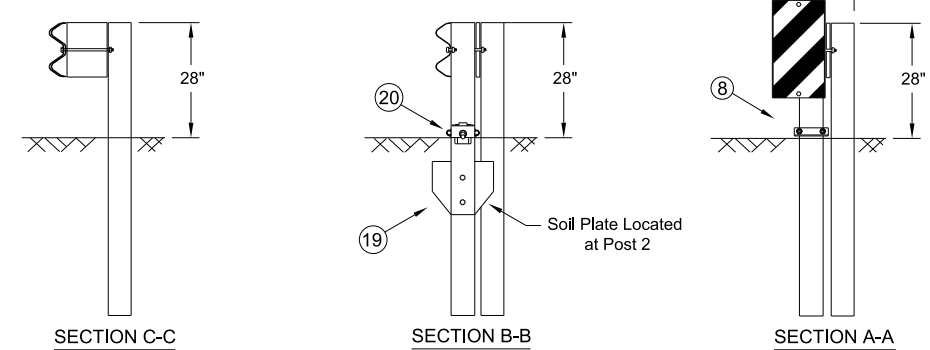

GENERAL NOTES

- For additional information contact: Lindsay Transportation Solutions - Barrier Systems, 180 River Road, Rio Vista, CA 94571, (707) 374-6800
- All dimensions are shown in inches except as otherwise indicated.
- All cable assemblies, cable anchor, ground struts, slider pieces, impact heads, nuts, bolts and all steel components shall be galvanized unless otherwise is noted.
- X-LITE placed within the minimum 150 ft. radius shall be installed straight. Standard rail elements may be installed within the radius without special fabrication.
- A flare rate of 37.5:1 may be used over the first 50 ft. of the system to prevent the terminal head from encroaching on the shoulder the flare may be decreased or eliminated for specific installations, or as directed by the engineer.
- At curbed locations the post shall be installed at the proper grade of elevation behind the curb. The post will then require field drilling new holes to accommodate the rail to post connection bolt to maintain the proper height of the rail above the gutter pan. The excess post length above the rail will be removed as directed by the engineer.
- If rock excavation is encountered, the soil plate maybe modified if approved by the project engineer.
- When site conditions permit, post may be driven. If posts are placed in a drilled hole, the backfill material must be satisfactorily compacted to prevent settlement.
- An object marker shall be installed on the impact head as detailed on D&OM(VIA)
- The X-LITE is a steel post SGT that is suitable for locations calling for wood post or steel post MBGF systems. When used with wood post guardrail system, post 7 thru 9 may be replaced with CRT posts.
- Minimum length of MBGF shown. See current guard fence Standards for further information.
- The breakaway cable assembly must be taut. A locking device (vice-grips or channel lock-pliers) should be used to prevent the cable from twisting when tightening the nut.

ITEM	PART NO.	DESCRIPTION	QTY
1	BSI-1310027-00	X-LITE, CRIMPED POST HOLES, GALV	1
2	BSI-1012086-00	POST II, X-LITE, GALV	1
3	BSI-1012078-00	LINE POST, X-LITE, GALV	6
4	BSI-1012103-00	IMPACT HEAD, X-LITE, GALV	1
5	BSI-1012093-00	SLIDER PANEL, FRONT, X-LITE, GALV	1
6	BSI-1012090-00	SLIDER BRACKET, X-LITE	1
7	BSI-1012096-00	BACK SLIDER PANEL, X-LITE, GALV	1
8	BSI-1102001-KT	GROUND STRUT KIT, X-LITE	1
9	BSI-1012104-00	CABLE ANCHOR ASSEMBLY, X-LITE	1
10	K080123	KIT, X-TENSION SHEAR BOLT,	2
11	BSI-1102027-00	WASHER, SQUARE, X-LITE, GALV	1
12	B090534	W-BEAM COMPOSITE BLOCKOUT 8 IN,	7
13	4001115	GUARDRAIL BOLT 5/8"-11X1 1/4"	24
14	2000302	BOLT CH 5/8"-11X2	2
15	2001635	BOLT CH 5/8"-11X10" GRADE 5 MGAL	7
16	4001116	GUARDRAIL NUT RECESSED 5/8"-11	33
17	2001580	WASHER 1 F436 FLAT RD STRUCT	1
18	4000443	W-BEAM GUARDRAIL RWM02a	4
19	BSI-1106016-KT	X-LITE, SOIL PLATE KIT	1
20	BSI-1303005-00	BRACKET, X-LITE CABLE RETENTION	1
21	BSI-1310024-00	X-LITE, CRIMPED POST SLOTS, GALV	1
22	MANXLT	X-LITE TANGENT INSTALLATION MANUAL	1



**SINGLE GUARDRAIL TERMINAL
(X-LITE)
STEEL POST
SGT(9S)28-14**

FILE: sg19s2814.dgn	DN: TxDOT	CK: RM	DW: VP	CK: CGL
© TxDOT: JULY 2014	CONT	SECT	JOB	HIGHWAY
REVISIONS				
DIST	COUNTY			SHEET NO.

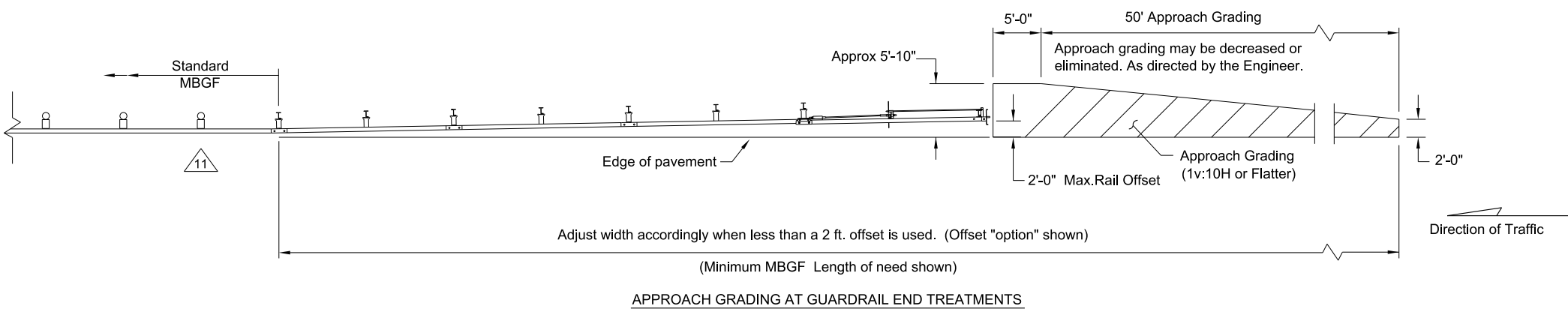

APPROACH GRADING AT GUARDRAIL END TREATMENTS