

DISCLAIMER: This standard is prepared by the "Texas Engineering Practices Act". Its use by any kind is made by TxDOT for any purpose whatsoever. TxDOT assumes no responsibility for the conversion of this standard to other formats or for incorrect results or damages resulting from its use.

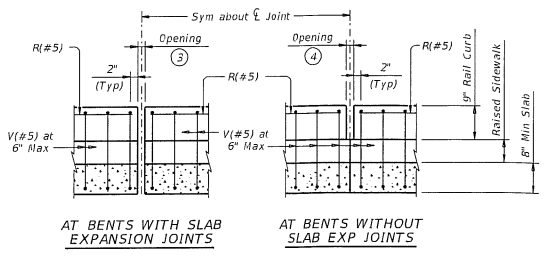
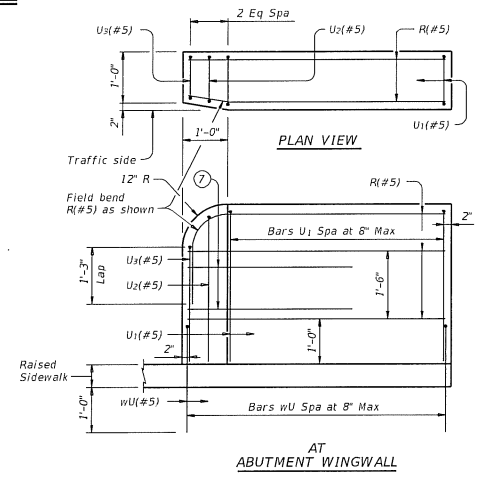
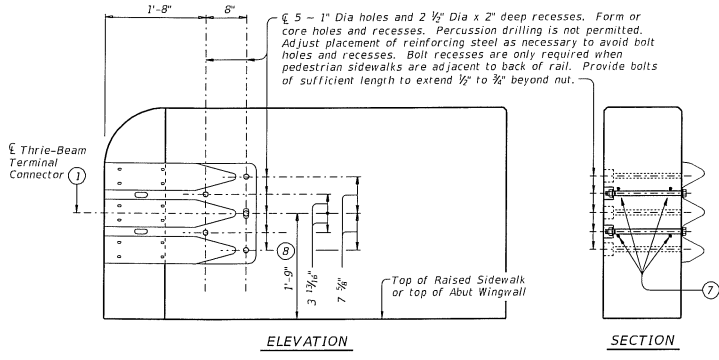
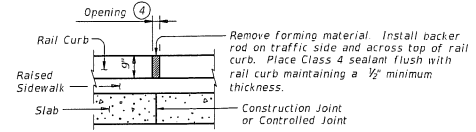
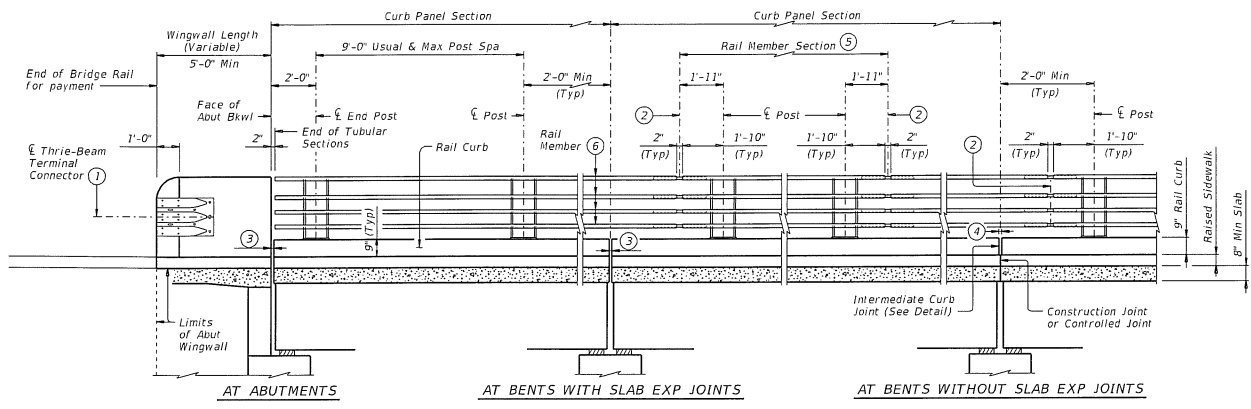

- ① Terminal Connectors and associated hardware are to be paid for under the Item "Metal Beam Guard Fence". Attach Metal Beam Guard Fence Transitions to the bridge rail and extend along the embankment unless otherwise shown in the plans.
- ② Expansion Joint or Splice Joint as required.
- ③ Same as slab joint opening. (5' Max Expansion Joint).
- ④ 1/2" Min, 3/4" Max.
- ⑤ Rail member sections must have at least two posts but not more than four.
- ⑥ HSS 6 x 2 x 1/4 (ASTM-A1085 or A500 Grade B).
- ⑦ Place 4 additional Bars R(#5) 3'-8" in length inside Bars U(#5) and centered 2'-0" from end of rail when Terminal Connections are required. Field bend as needed.
- ⑧ Increase 2" for structures with Overlay.

		Bridge Division Standard	
<b>COMBINATION RAIL</b>			
<b>TYPE CIW</b>			
FILE: r1stc017-18.dgn	DW: TxDOT	BY: TxDOT	DN: JFR
① TxDOT	March 2018	CENT	SECT
REVISIONS		DATE	COUNT
DRAWN		CHECKED	APPROVED

DATE: TITLE:

DISCUSS: USER  
 The use of this standard is governed by the Texas Engineering Practice Act. No warranty of any kind is made by TxDOT for any purpose whatsoever. TxDOT assumes no responsibility for the conversion of this standard to other formats or for incorrect results or damages resulting from its use.

DATE: \_\_\_\_\_  
 PLZ: \_\_\_\_\_

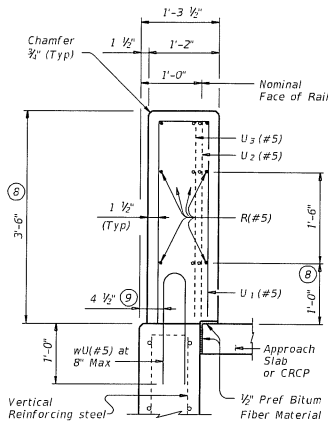

**ON ABUTMENT WINGWALLS  
OR CIP RETAINING WALLS**

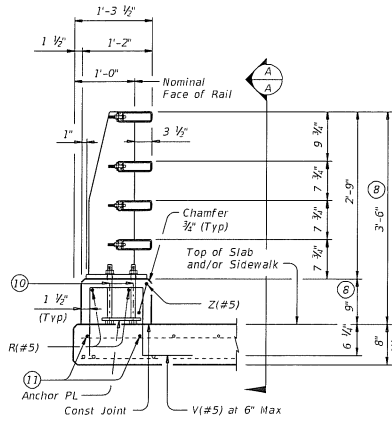

**ON BRIDGE SLAB**

**SECTIONS THRU RAIL WITHOUT RAISED SIDEWALK**

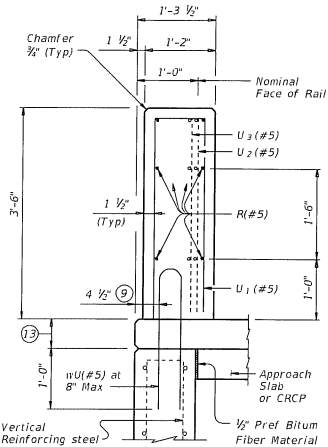

**ON ABUTMENT WINGWALLS  
OR CIP RETAINING WALLS**

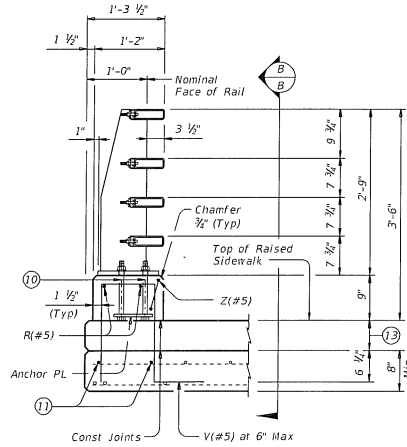

**ON BRIDGE SLAB**

**SECTIONS THRU RAIL WITH RAISED SIDEWALK**

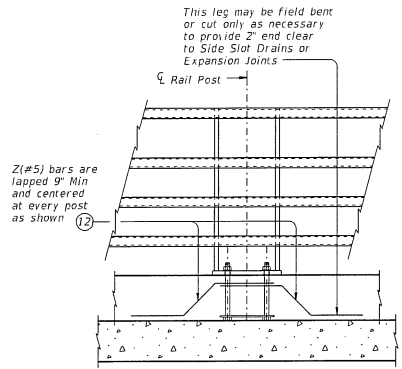

**VIEW A-A**  
 Bars V and R omitted for clarity.  
 Showing without raised sidewalk.

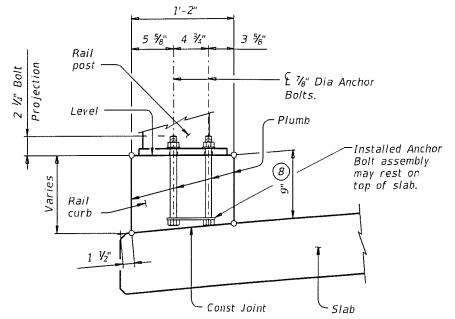

**WITHOUT RAISED SIDEWALK**

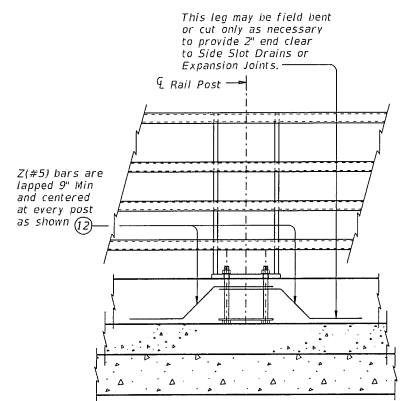

**VIEW B-B**  
 Bars V and R omitted for clarity.  
 Showing with raised sidewalk.

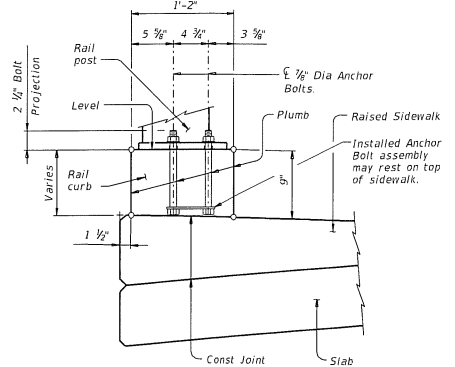

**WITH RAISED SIDEWALK**

**RAIL CURB FORMING DETAIL**

Reinforcing steel and rail curb chamfers not shown for clarity.

- ⑧ Increase Z' for structures with Overlay.
- ⑨ 5 1/2" when vertical reinforcing has closer clear cover over horizontal reinforcing in abutment wingwalls or retaining walls on traffic side of wall.
- ⑩ 1/2" Dia Anchor Bolts. See "Anchor Bolt Assembly Details".
- ⑪ Top longitudinal slab bar may be adjusted laterally 3" plus or minus to tie reinforcing.
- ⑫ Adjust Bars Z(#5) as necessary to avoid Bars V(#5).
- ⑬ Raised Sidewalk.

SHEET 2 OF 4

<b>COMBINATION RAIL</b>			
<b>TYPE CIW</b>			
PRE: 1/16/07-1850n TxDOT March 2018 REVISIONS	DES: _____ SEC: _____ CON: _____ SHEET NO.	DR: JTR DES: _____ SEC: _____ CON: _____ SHEET NO.	CH: JHN DES: _____ SEC: _____ CON: _____ SHEET NO.

DISCLAIMER: This standard is governed by the Texas Engineering Practices act. No warranty of any kind is made by TxDOT for any purpose whatsoever. TxDOT assumes no responsibility for the condition of this standard or for incorrect results or damages resulting from its use.

DATE: \_\_\_\_\_  
 TITLE: \_\_\_\_\_

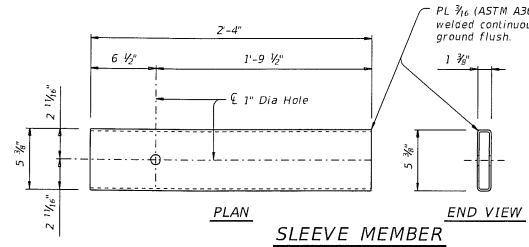

**SLEEVE MEMBER**

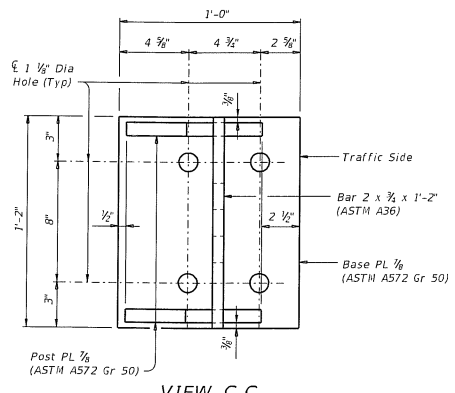

**VIEW C-C**  
 (Showing Hole location in Base PL)

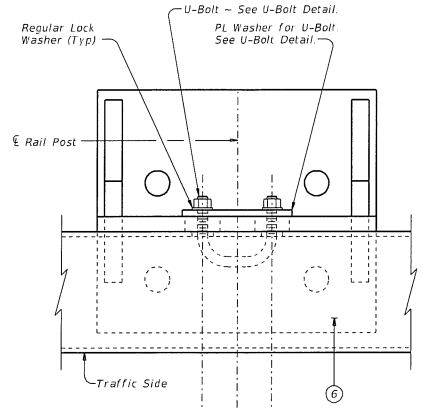

**TOP VIEW OF RAIL POST**  
 (Showing connection for rail post and HSS.)

1 1/2" Dia Holes vertically centered in HSS to accommodate U-Bolt connection with Post. Connection typical for all HSS.

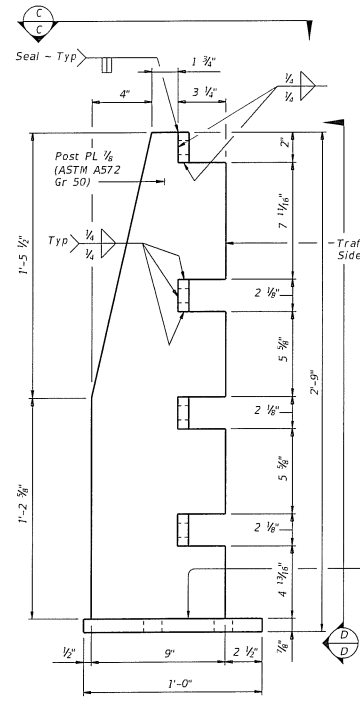

**POST DETAIL**

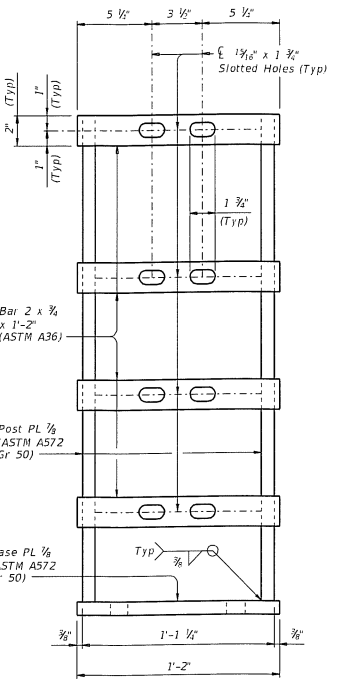

**VIEW D-D**

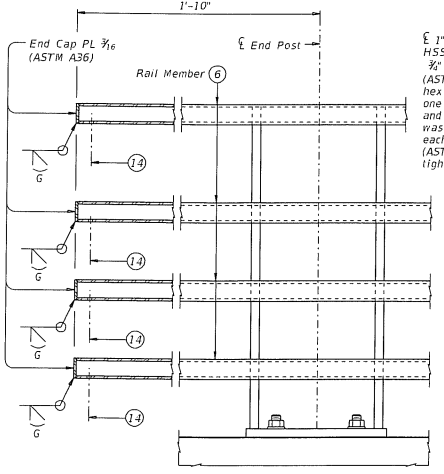

**END CAPS ON HSS AT END POST**

1" Dia holes in HSS centered for 3/4" Dia x 3 1/2" (ASTM F3125 Gr A325) hex head bolts with one regular washer and one regular lock washer placed under each heavy hex nut (ASTM A563). Wrench tight, do not crush rail.

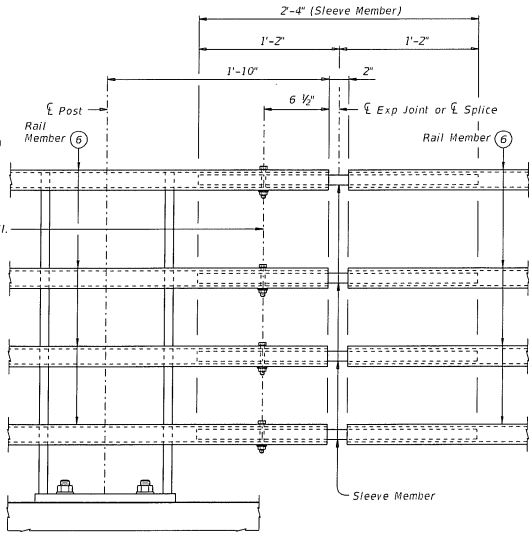

**EXPANSION JOINT OR SPLICE**

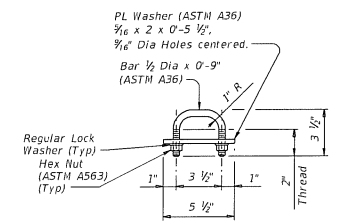

**U-BOLT DETAIL**  
 (Showing U-Bolt for rail post and HSS.)

- Ⓢ HSS 6 x 2 x 1/4 (ASTM A1085 or A500 Grade B).
- Ⓣ 1 1/2" Dia Drain Hole in bottom of HSS.

SHEET 3 OF 4

<b>COMBINATION RAIL</b>			
<b>TYPE CIW</b>			
FILE: 11st0017-18.dgn	DN: TADOT	CK: TADOT	DR: JTR
REV: 01 TADOT March 2018	CON: SECT	JOB: MSH&M	
REVISIONS	DATE	DESCRIPTION	SHEET NO.

DISCLAIMER: This standard is governed by the Texas Engineering Practices Act. No warranty of any kind is made by TxDOT for any purpose whatsoever. TxDOT assumes no responsibility for the conformance of this standard to other formats or for incorrect results or damages resulting from its use.

DATE: \_\_\_\_\_  
 FILE: \_\_\_\_\_

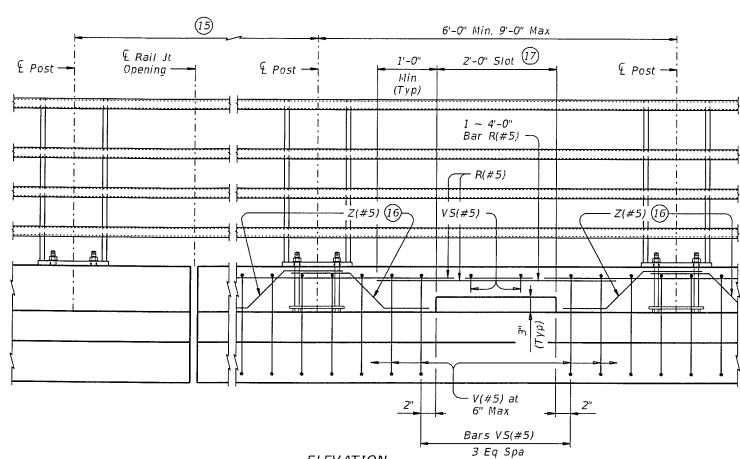

ELEVATION

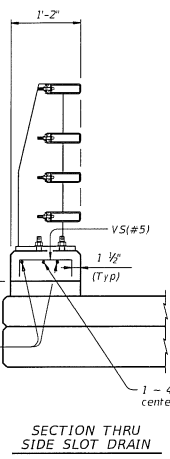

SECTION THRU SIDE SLOT DRAIN

**OPTIONAL SIDE SLOT DRAIN DETAILS**

Showing side slot drain on raised sidewalk, without raised sidewalk similar.

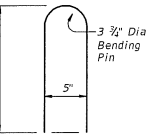
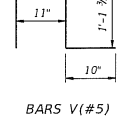
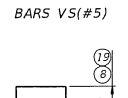
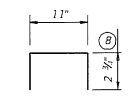

BARS wU(#5)

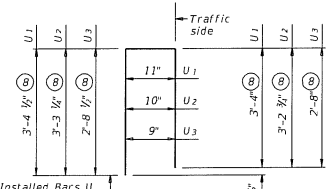

BARS U(#5)

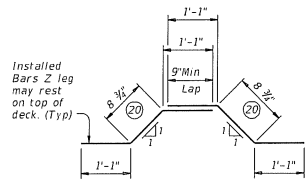

BARS Z(#5)

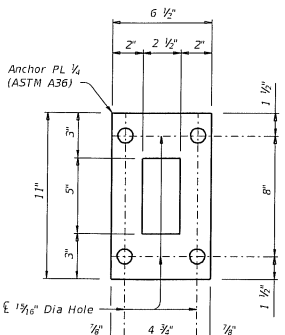

PLAN OF ANCHOR PLATE

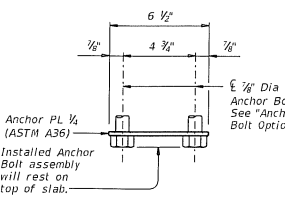

ELEVATION

- 8 Increase Z" for structures with Overlay.
- 13 Side slot drains are not allowed in areas where there is a joint in the concrete curb between rail posts.
- 16 Bars Z(#5). See "Section Thru Rail" and "View A-A or B-B" for Bar Z placement and spacing.
- 17 Center side slot drain between posts within the limits shown.
- 18 Side slot drains may be used where shown elsewhere on the plans or as directed by the Engineer. Do not place drains over railroad tracks, lower roadways, or sidewalks. When this rail is used as a separator between a roadway and a sidewalk, side slot drains are not permitted.
- 19 For raised sidewalks, add sidewalk height to total bar height. Use sidewalk height at rail's location.
- 20 Increase 2 3/4" for structures with Overlay.

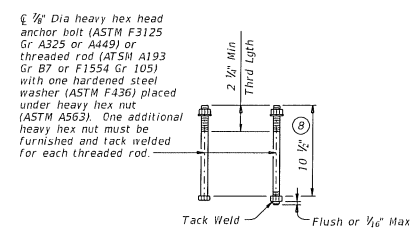

**ANCHOR BOLT OPTIONS**

(Showing Anchor Bolts for Base Plate)

**ANCHOR BOLT ASSEMBLY DETAILS**

**CONSTRUCTION NOTES:**  
 The face of tubular sections and rail curb must be plumb unless otherwise approved by the Engineer. Steel posts must be square to the top of curb. Use Type VIII epoxy mortar under post base plates if gaps larger than 1/8" exist.  
 Bend tubes to required radius for curved rails. Shop drawings for approval are required for curved rails.  
 One shop splice per rail member section is permitted with minimum 85 percent penetration. The weld may be square groove or single vee groove. Grind smooth.  
 Round or chamfer exposed edges of rail members and rail posts must be rounded or chamfered to approximately 1/8" by grinding.  
 Chamfer all exposed concrete corners.

**MATERIAL NOTES:**  
 Provide ASTM A1085 or A500 Gr B for all HSS.  
 Provide Grade 60 reinforcing steel.  
 Epoxy coat or galvanize all reinforcing steel if slab bars are epoxy coated or galvanized.  
 Galvanize all metal components of steel rail system. Apply additional coatings when shown elsewhere on the plans. When plans require paint over galvanizing, follow the requirements for painting galvanized steel in Item 445, "Galvanizing" and when field painting, Item 446, "Field Cleaning and Painting Steel". Sleeve members and anchor bolts must receive galvanization prior to installation and only field paint after installation unless directed otherwise by Engineer.  
 Provide 3/8" Dia ASTM F3125 Gr A325 or A449 bolts (or ASTM A193 Gr B7 or F1554 Gr 105 threaded rods with one tack welded heavy hex nut each) with one hardened steel washer (ASTM F436) placed under each heavy hex nut that conforms to ASTM A563 requirements.  
 Provide 1/2" Dia round bar U-bolts (ASTM A36) with plate washer (ASTM A36) and regular lock washers placed under hex nuts that conform to ASTM A563 requirements. See "U-Bolt Detail".  
 Provide Class "S" concrete. When Class "S" concrete for slab is HPC, include a minimum of 3 gallons of calcium nitrite inorganic corrosion inhibitor per cubic yard of Class "S" concrete.  
 Provide bar laps, where required, as follows:  
 Uncoated or galvanized - #5 = 2'-0"  
 Epoxy coated - #5 = 3'-0"

**GENERAL NOTES:**  
 This rail has been evaluated and accepted to be of equal strength to railings with like geometry, which have been crash tested to meet NCHRP Report 350 TL-3 criteria. This rail can be used for speeds of 50 mph and greater when a TL-3 rated guard fence transition is used. When a TL-2 rated guard fence transition is used, this rail can only be used for speeds of 45 mph and less.  
 This railing cannot be used on bridges with expansion joints providing more than 5" movement or on cast-in-place retaining walls, unless otherwise noted.  
 Rail anchorage details shown on this standard may require modification for select structure types. See appropriate details elsewhere in plans for these modifications.  
 Submit erection drawings showing panel lengths, rail post spacing, and anchor bolt setting, to the Engineer for approval.  
 Average weight of railing with no overlay:  
 205 plf total  
 131 plf (Conc)  
 74 plf (Steel).

Cover dimensions are clear dimensions, unless noted otherwise. Reinforcing bar dimensions shown are out-to-out of bar.

**COMBINATION RAIL**

**TYPE CIW**

FILE	H142017-18.dgn	DR	TxDOT	CK	TxDOT	DES	JTR	CR	JHM
REVISED	March 2018	COST	SECT	NOB	ALSO IN				
REVISIONS									
BY	DATE	REASON	BY	DATE	REASON	BY	DATE	REASON	BY