

DISCLAIMER: The use of this standard is governed by the Texas Engineering Practice Act. No warranty of any kind is made by the Texas Department of Transportation for the accuracy or conversion of this standard to other formats or for incorrect results or damages resulting from its use.

DATE: FILE:

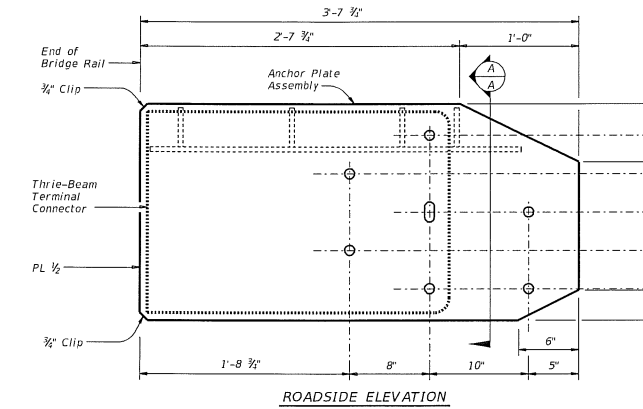
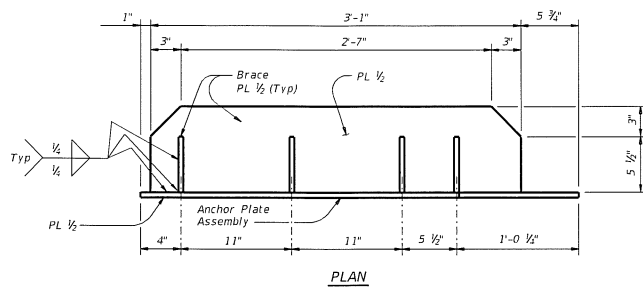

ANCHOR PLATE DETAILS

Anchor Plate shown is detailed for one end of one side of rail only. For other side, Anchor Plate must be built opposite hand.

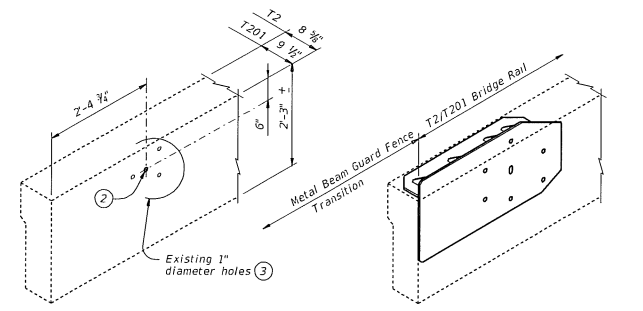

INSTALLATION DETAILS

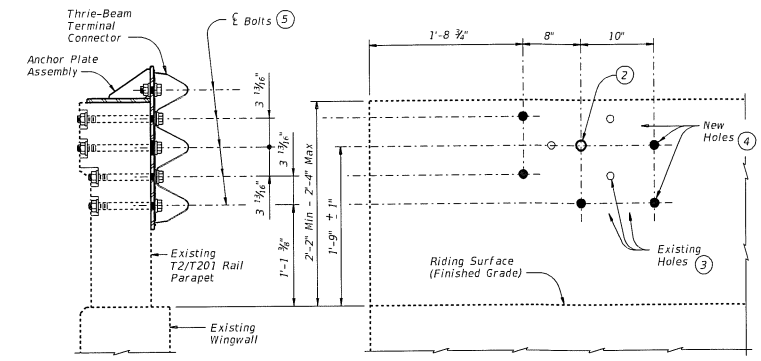
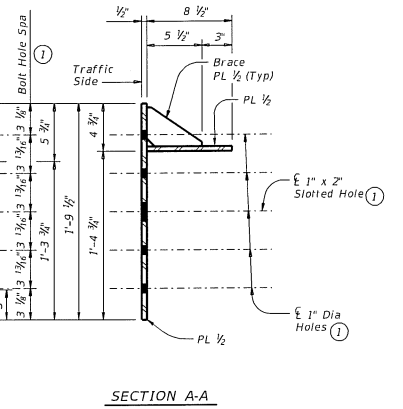
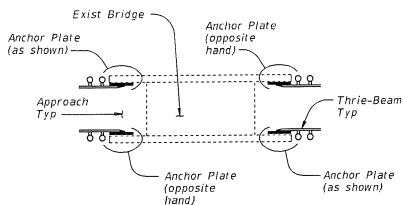

THRIE-BEAM TERMINAL CONNECTION DETAILS ①

CONSTRUCTION NOTES:
Field verify dimensions before commencing work and ordering materials.
On T2 rail remove any MBGF (W-beam) and attachment hardware from the face of rail if present, prior to installation of new MBGF Transition. Dispose of these materials as directed by the Engineer. Plugging of newly exposed existing bolt holes is not necessary except as stated here in or otherwise indicated on the plans. This work is considered subsidiary to the pertinent bid items.
Attach the MBGF Transition to the existing parapet using the Anchor Plate assembly and the Thrie-Beam Terminal Connector. Splice the Thrie-Beam Terminal Connection and Thrie-Beam with the normal 12 connection bolts. Refer to Metal Beam Guard Fence Transition and Metal Beam Guard Fence detail sheets for additional details and information not shown herein.

MATERIAL NOTES:
Fabricate Anchor Plate assembly with steel conforming to either ASTM A36 or A572 Gr 50. Anchor Plate assembly must be free of burrs, sharp edges and weld splatter. Grind edges and corners to a 1/8" flat or radius. Hot-dip galvanize Anchor Plate assembly in accordance with Item 445, "Galvanizing". Anchor bolts, nuts, and washers must conform to Item 449, "Anchor Bolts".

GENERAL NOTES:
These details are for retrofitting existing rails only, not new construction, with a Thrie-Beam Terminal Connection.
Shop drawings are not required for this installation.
Materials, fabrication and installation of this assembly are to be included in the price bid for "Metal Beam Guard Fence Transition". Estimated weight of a single Anchor Plate assembly, including bolts, nuts, and washers, but not including the Thrie-Beam Terminal Connector = 190 Lbs.

This sheet is intended as a guide in preparing job-specific details to retrofit existing T2 or T201 rails with a Thrie-Beam terminal connector. This sheet may not be used without modification. The details shown may need to be amended if the exact existing conditions are not covered. In all cases, details and notes not required are to be removed or crossed out, "NOC" added, and the phrase "Not to be used as a standard" removed from the title block. This sheet must be signed, sealed, and dated by a registered Professional Engineer. The effective height of the existing rail (at the Anchor Plate location) above the finished riding surface, as seen by an errant vehicle, must be between 2'-2" and 2'-4". Alternate methods of retrofit must be used for effective heights beyond these limits. Dimensions of existing rail height (traffic side) should be shown. Particular care should be taken in identifying existing rail conditions and providing for proper Anchorage Plate and MBGF transition positioning.

- ① The Contractor must verify that locations of bolt holes match those in the Thrie-Beam Terminal Connector to be installed in that location, prior to fabrication of Anchor Plate assembly and prior to coring bolt holes in the existing T2/T201 parapet.
- ② If the existing holes are aligned as expected, use the indicated existing 1" diameter hole in the installation of the Anchor Plate assembly and the Thrie-Beam Terminal Connector.
- ③ If the existing holes are not aligned as expected, holes that cannot be utilized in the installation and are within 3" of a new bolt hole must be filled with epoxy grout prior to coring new holes.
- ④ Drill new 1" diameter holes, each with a 2 1/2" diameter x 1" deep recess, through existing railing parapet. Note that recesses are only required when pedestrian sidewalks are adjacent to back of rail unless directed otherwise by the Engineer. Holes should be perpendicular to the roadside face of the parapet. Drill holes and recesses with coring type equipment. Percussion drilling is not allowed. Patch spalls, when directed by the Engineer, in accordance with Item 429, "Concrete Structure Repair", at the Contractor's expense.
- ⑤ 7 - 7/8" diameter ASTM F3125 Gr A325 Hex Head Anchor Bolts each with 2 - 1 3/4" O.D. washers. Place washer under each head and nut. Provide bolts of sufficient length to extend a minimum of 1/2" beyond nut. Cut excess bolt length and paint cut surface with zinc-rich paint if directed by the Engineer.

Texas Department of Transportation		Bridge Division Standard	
T2/T201 TRANSITION RETROFIT GUIDE			
(NOT TO BE USED AS A STANDARD)			
T2/T201TR			
FILE: 1/15/02S-18.dgn	OK: TADOT	EX: TADOT	DN: TADOT
DATE: March 2019	CONF: []	SECT: 108	HSN: 64
REVISIONS			
DISK	COUNT	SHEET 108	