

DISCLAIMER: The use of this standard is governed by the "Texas Engineering Practice Act". No warranty of any kind is made by TxDOT for any purpose whatsoever. TxDOT assumes no responsibility for the conversion of this standard to other formats or for incorrect results or damages resulting from its use.

Wedge Anchor Steel System

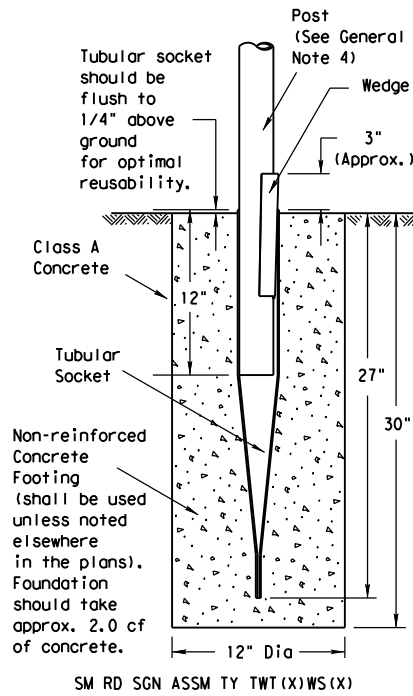

Wedge Anchor High Density Polyethylene (HDPE) System

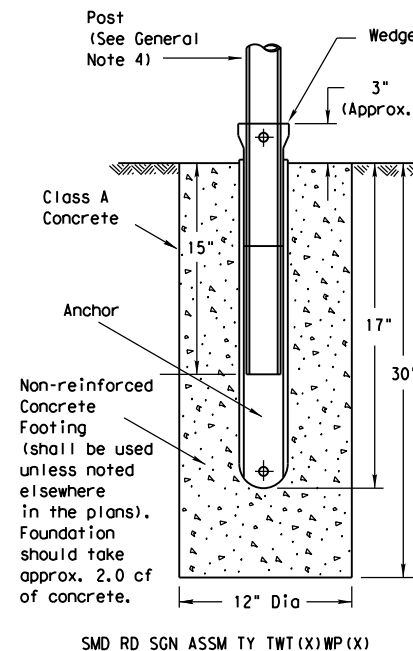

Universal Anchor System with Thin-Walled Tubing Post

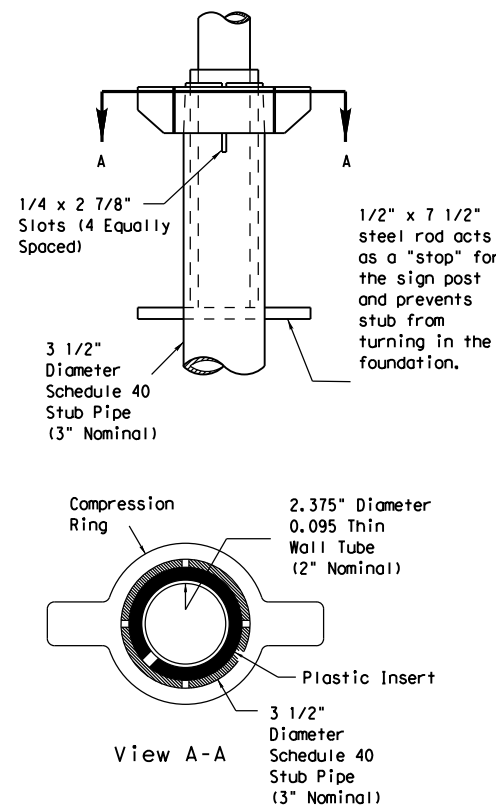
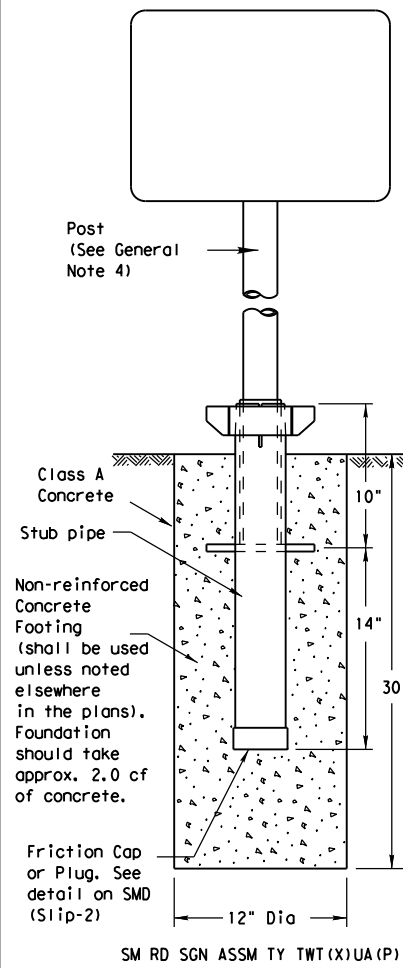

Plastic insert must be used when using the TWT with either the Universal Anchor System or the Bolt Down Universal Anchor System. The insert should be approx. 10" long and cover the tubing from just above the top of the stub pipe to the bottom of the sign post when using the Universal Anchor System. The insert should be cut to approx. 4 1/2" when used with the Bolt Down Universal Anchor System.

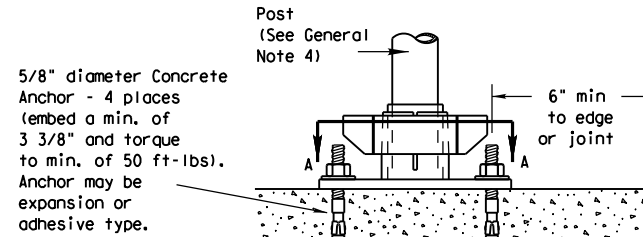

Concrete anchor consists of 5/8" diameter stud bolt with UNC series bolt threads on the upper end. A heavy hex nut per ASTM A563 and hardened washer per ASTM F436. The stud bolt shall have minimum yield and ultimate tensile strengths of 50 and 75 ksi, respectively. Nuts, bolts and washers shall be galvanized per Item 445, "Galvanizing." Top of bolt shall extend at least flush with top of nut when installed. The anchor, when installed in 4000 psi normal-weight concrete with a 3 3/8" minimum embedment, shall have a minimum allowable tension and shear of 2450 and 1525 psi, respectively. Adhesive type anchors shall have stud bolts installed with Type III epoxy per DMS-6100, "Epoxyes and Adhesives." Adhesive anchors may be loaded after adequate epoxy cure time per the manufacturer's recommendations.

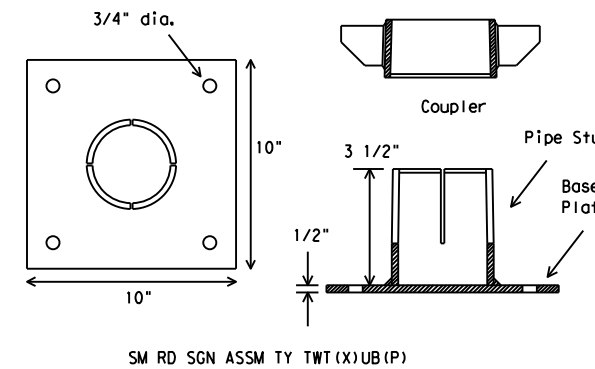

Sign Installation Using a Prefabricated T-Bracket for Thin-Wall Tubing Post

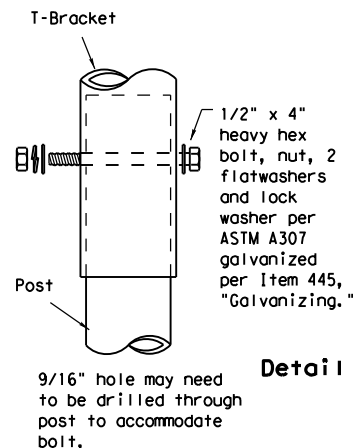
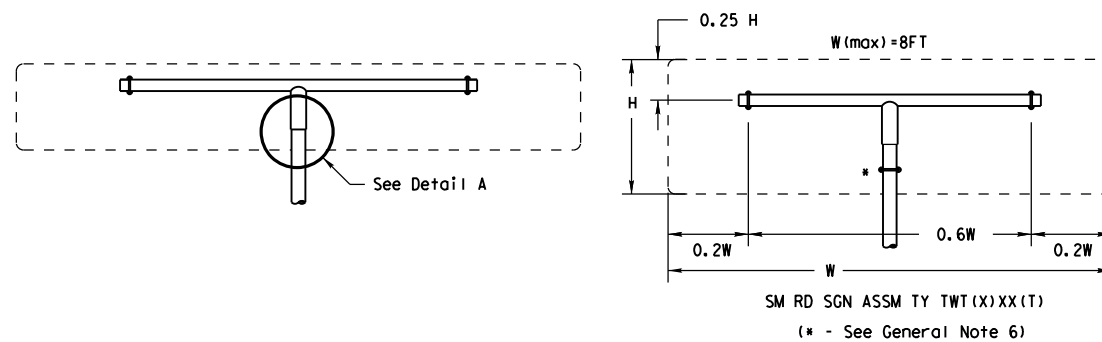

NOTE
The devices shall be installed per manufacturer's recommendations. Installation procedures shall be provided to the Engineer by Contractor.

GENERAL NOTES:

- The Wedge Anchor System and the Universal Anchor System with thin wall tubing post may be used to support up to 10 square feet of sign area.
- The tubular socket, wedge and prefabricated T-bracket shall be permanently marked to indicate manufacturer. Method, design, and location of marking are subject to the approval of the TxDOT Traffic Standards Engineer.
- Except for posts (13 BWG Tubing), clamps, nuts and bolts, all components shall be prequalified. A list of prequalified vendors may be obtained from the Material Producer List web page. The website address is: http://www.txdot.gov/business/producer_list.htm
- Material used as post with this system shall conform to the following specifications:
13 BWG Tubing (2.375" outside diameter) (TWT)
0.095" nominal wall thickness
Seamless or electric-resistance welded steel tubing
Steel shall be HSLA Gr 55 per ASTM A1011 or ASTM A1008
Other steels may be used if they meet the following:
55,000 PSI minimum yield strength
70,000 PSI minimum tensile strength
18% minimum elongation in 2"
Wall thickness (uncoated) shall be within the range of .083" to .099"
Outside diameter (uncoated) shall be within the range of 2.369" to 2.381"
Galvanization per ASTM 123 or ASTM A653 G210. For precoated steel tubing (ASTM A653), recoat tube outside diameter weld seam by metallizing with zinc wire per ASTM B833.
- Sign blanks shall be the sizes and shapes shown on the plans.
- Additional sign clamp required on the "T-bracket" post for 24" high signs. Place clamp at least 3" above bottom of sign when possible.
- Sign supports shall not be spliced except where shown. Sign support posts shall not be spliced.
- See the Traffic Operations Division website for detailed drawings of sign clamps and Wedge Anchor System components. The website address is: <http://www.txdot.gov/publications/traffic.htm>

WEDGE ANCHOR SYSTEM INSTALLATION PROCEDURE

- Dig foundation hole. Where solid rock is encountered at ground level, the foundation shall be a minimum depth of 18". When solid rock is encountered below ground level, the foundation shall extend in the solid rock a minimum depth of 18" or provide a minimum foundation depth of 30". If solid rock is encountered, the socket/stub may be reduced in length as required to a minimum length of 18". Any material removed from the socket/stub shall be from the bottom and the clearance requirements given on SMD(GEN) must be followed. The inner surfaces of the socket/stub must remain free of concrete or other debris.
- The Engineer may permit batches of concrete less than 2 cubic yards to be mixed with a portable, motor driven concrete mixer. For small placements less than 0.5 cubic yards, hand mixing in a suitable container may be allowed by Engineer. Place concrete into hole until it is approximately flush with the ground. Concrete shall be Class A.
- Insert tubular socket into concrete until top of socket is approximately 1/4" above the concrete footing.
- Plumb the socket. Allow a minimum 4 days for concrete to set, unless otherwise directed by Engineer.
- Attach the sign to the sign post.
- Insert the sign post into socket and align sign face with roadway.
- Drive the wedge into the socket to secure post. This will leave approximately 3 inches of the wedge exposed.

UNIVERSAL ANCHOR SYSTEM INSTALLATION PROCEDURE

- Dig foundation hole. Where solid rock is encountered at ground level, the foundation shall be a minimum depth of 18". When solid rock is encountered below ground level, the foundation shall extend in the solid rock a minimum depth of 18" or provide a minimum foundation depth of 30". If solid rock is encountered, the socket/stub may be reduced in length as required to a minimum length of 18". Any material removed from the socket/stub shall be from the bottom and the clearance requirements given on SMD(GEN) must be followed. The inner surfaces of the socket/stub must remain free of concrete or other debris.
- Insert base post in hole to depths shown and backfill hole with concrete.
- Level and plumb the base post using a torpedo level and allow concrete adequate time to set. The bottom of the slots provided in the stub pipe shall remain above the top of the concrete foundation.
- Attach the sign to the sign post.
- Install plastic insert around bottom of post.
- Insert sign post into base post. Lower until the post comes to rest on steel rod.
- Seat compression ring using a hammer. Typically, the top of compression ring will be approximately level with top of stub post when optimally installed.
- Check sign post by hand to ensure it is unable to turn. If loose, increase the tightening of the compression ring.

Texas Department of Transportation
Traffic Operations Division

SIGN MOUNTING DETAILS SMALL ROADSIDE SIGNS WEDGE & UNIVERSAL ANCHOR WITH THIN WALL TUBING POST SMD (TWT) -08

© TxDOT July 2002	DN: TxDOT	CK: TxDOT	DW: TxDOT	CK: TxDOT
9-08	REVISIONS	CONT	SECT	JOB
				HIGHWAY
				SHEET NO.